

Testing Animal Identification Implants

Customer Inquiry

One of QuadTech's customers is a manufacturer of animal ID implants, an electronic device implanted in animals giving them a unique identification number. These devices can be used for absolute identification of exotic animals and birds should they become lost or stolen. The unit basically consists of an integrated circuit, a small capacitor and coil sealed in a glass tube and usually implanted in the shoulder blade region of the animals body. This micro chip (about the size of a grain of rice) lies dormant and is only activated by radiation through a built-in antenna which charges the internal capacitor causing the animals ID code to be read back through the same antenna to an external receiving device (scanner).



QuadTech Solution

100% inductance testing on the coils and sample testing of the capacitors is a vital step in the manufacturing process. With no internal testing capabilities this company found it necessary to employ the services of an outside test house. With the introduction of the 7400 Precision LCR Meter, this manufacturer is now able to measure product components and other devices within the company.

Measurement Procedure

The capacitor and coil used in the ID implant are critical components to the long-term operation of this device, expected to last for the life of the animal. The production process at this company requires 100% testing of the coil at 125kHz on the 7400 LCR Meter. The 7400 instrument is also used as a QC tool for lot sample testing of the capacitor, which when combined with the coil makes up a matched pair. The manufacturer is using the 7400 unit as an R&D tool to test new components at various frequencies.

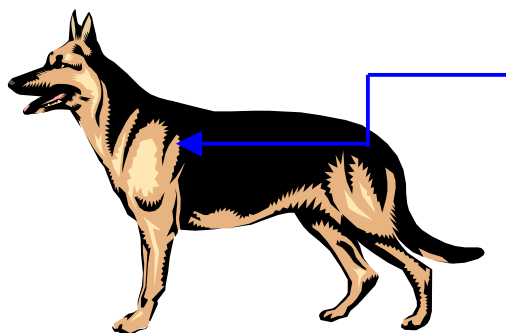

Location of ID implant
(Shoulder Blade)

What's that look like?

Figure 1 illustrates the connection of the 7400 Precision LCR Meter to the device under test, the coil and the capacitor used in the animal ID implant microchip.

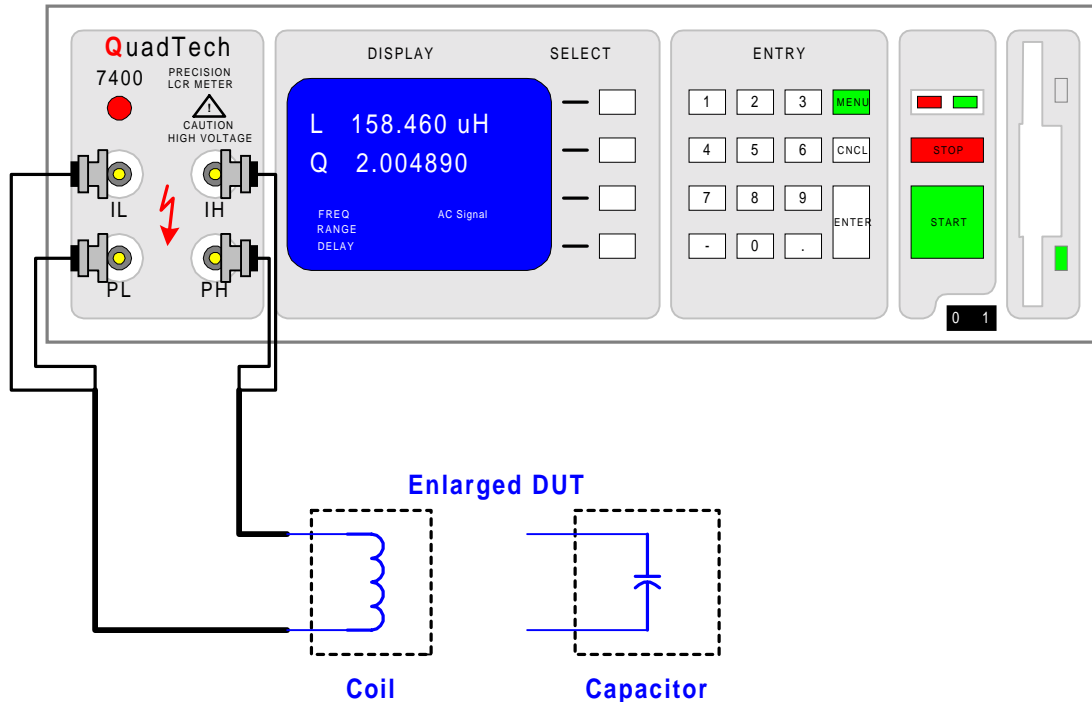

Figure 1: Connection of 7400 Precision LCR Meter to DUT

Summary

The introduction of the 7400 was viewed as a substantial cost savings move. It has allowed coil winding and testing operations to be brought in-house for better local control. The capability of wide frequency selection offers much flexibility in the development of new products. Noteworthy is the fact that the 7400 provided a company with little to no testing experience to be up and running so quickly, its ease-of-use stood out.

For complete product specifications on the 7000 Series Precision LCR meters or any of QuadTech's products, visit us at <http://www.quadtech.com/products>. Call us at 1-800-253-1230 or email your questions to info@quadtech.com.

The information presented here is subject to change and is intended for general information only

©QuadTech, Incorporated

Telephone: 1- 800-253-1230, Website: <http://www.quadtech.com>

Printed in U.S.A.

P/N 035058/A2

July 2003